

# All GNSS civilian signals

# TRIUMPH 3

Based on the TRIUMPH 3 chip with 864 channels

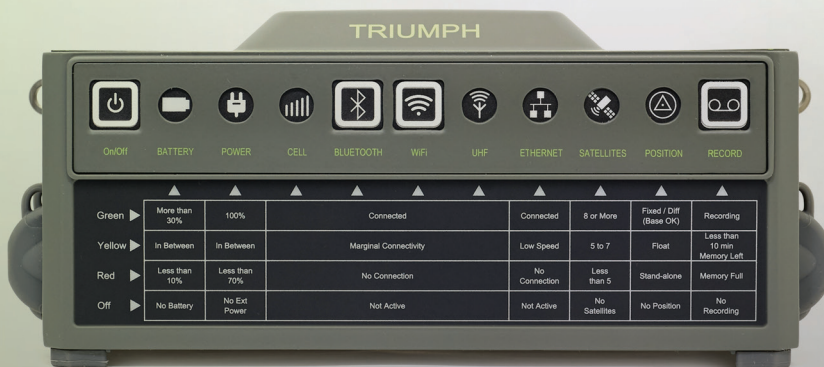

- Spread Spectrum • Bluetooth • UHF • 4G/LTE Cellular
- Wi-Fi • Integrated GNSS antenna

see back page >



## J-Mate Overview

6 pages inside >

After adding the high precision built-in inclinometer, now we added motorized auto focus for the J-Mate high precision camera

**NEW**

# J-Mate Quick Overview and Update to Videos

First let's set the record straight: J-Mate is not a total-station. J-Mate and TRIUMPH-LS **together** are a “**Total Solution**” which is a combination of GNSS, encoder and laser range measurements that **together** does a lot more than a total station. At long distances you use GNSS and at short distances (maximum of 100 meters) you use the J-Mate along with the TRIUMPH-LS. Together they provide RTK level accuracy (few centimeters) in ranges **from zero to infinity**.

One major improvement that we did recently is to add motorized control of the camera focus feature.

As with the TRIUMPH-LS, with the J-Mate we also provide software improvement updates regularly and free of charge. Download the J-Mate update in your TRIUMPH-LS and then inject it to the J-Mate. When you connect the TRIUMPH-LS to the J-Mate, the injection will be done automatically; but with your consent.

There are many new features in the J-Mate. We try to explain them in a few steps. Please also view the J-Mate videos in our website.

## Connecting J-Mate to TRIUMPH-LS:

TRIUMPH-LS communicates with the J-Mate through Wi-Fi. Turn on both the TRIUMPH-LS and the J-Mate. Click the Wi-Fi icon of the TRIUMPH-LS Home screen to connect to the J-Mate, much the same way as you connect TRIUMPH-LS to your Wi-Fi access point. J-Mate has ID of the form JMatexxx.

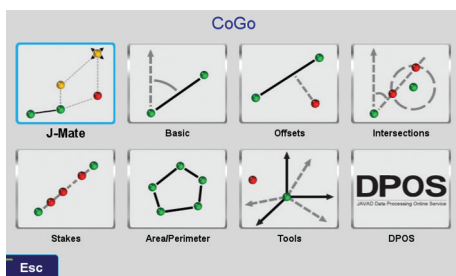
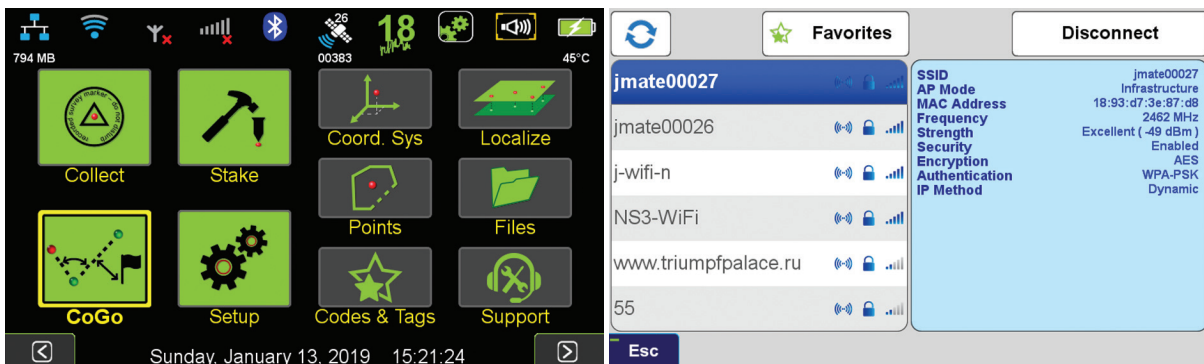

After connection, try to get acquainted with the **Main Navigation Screen**: On the TRIUMPH-LS Home screen, click CoGo/J-Mate/J-Mate Collect/Capture Target points.

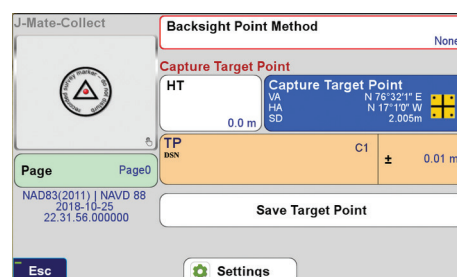
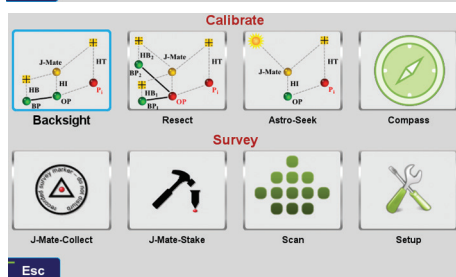

## Finding the target automatically:

There are three ways to search and find the target automatically:

- 1) One is by laser to scan and snap to a point when range changes by the specific amount. This is particularly valuable to snap to cables, poles and edges of buildings.
- 2) Second is search by laser for the object of the specific flat size and focus on its center, including the J-Target that we supply.
- 3) Third is with the camera to search for the J-Target. We will discuss these later.

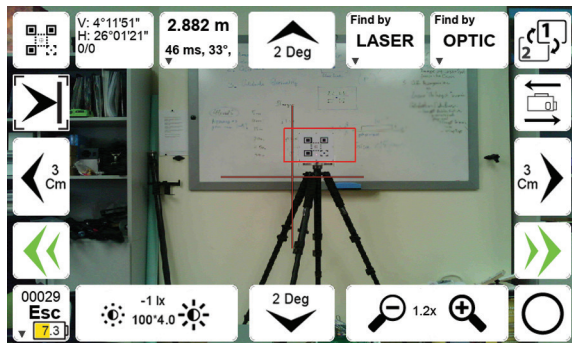

## Switching between the two cameras:

You can view the scenes by the wide-angle (about 60 degrees) camera of TRIUMPH-LS, while sitting on top of J-Mate; or by the narrow angle (about 5 degrees) precise camera of the J-Mate. Click Button “8” of Figure 1 to switch between the two. A rectangle on the wide angle camera of the TRIUMPH-LS shows the viewing area of the J-Mate camera which helps in aiming to targets.

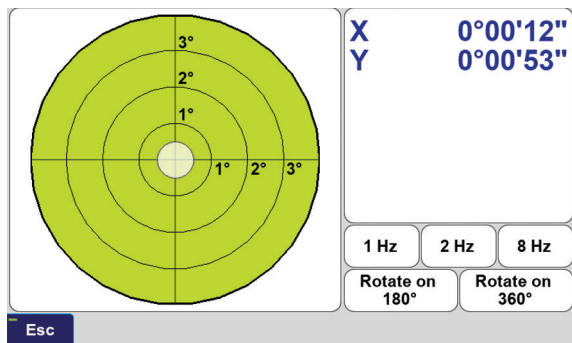

Figure 3

## Viewing the embedded Inclinometer:

Hold button “8” or click button “19” of Figure 1 to see the embedded 0.001-degree electronic inclinometer of the J-Mate as shown in Figure 3. It updates 10 times per second.

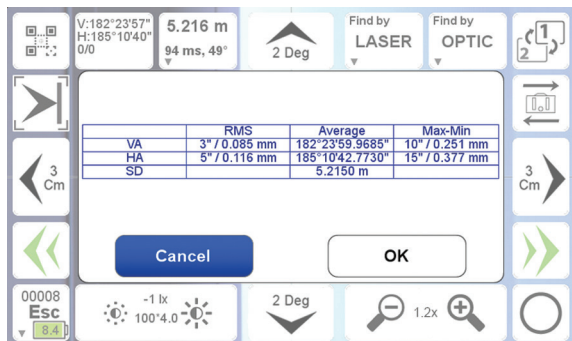

Figure 4

## Taking a point:

When you focus on your target manually or automatically, you can click the “Take” button (“10” in Figure 1). The Encoders will be measured 10 times, the average, RMS and spread will be shown and you can decide to accept or reject (Figure 4). The accepted points will be treated like RTK points but labelled as “JM” points.

You can also automatically take measurements around that point. Hold Button “10” to set up the area around the target.

You can access and treat them like any other points in the TRIUMPH-LS.

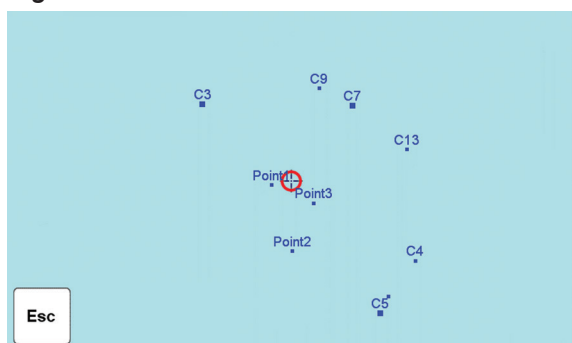

Figure 5

## Viewing the measured points:

Clicking button “7” in Figure 1 will change some control buttons. Hold it long and you will see live view of the points taken by J-Mate (Figure 5).

## Measuring angles quickly:

Aim at the first point and click button “2” of Figure 1. Then Aim to the second point and click this button again. You will see the horizontal angles between the two points. You can save the measured angles in clip boards and use it elsewhere when you need.

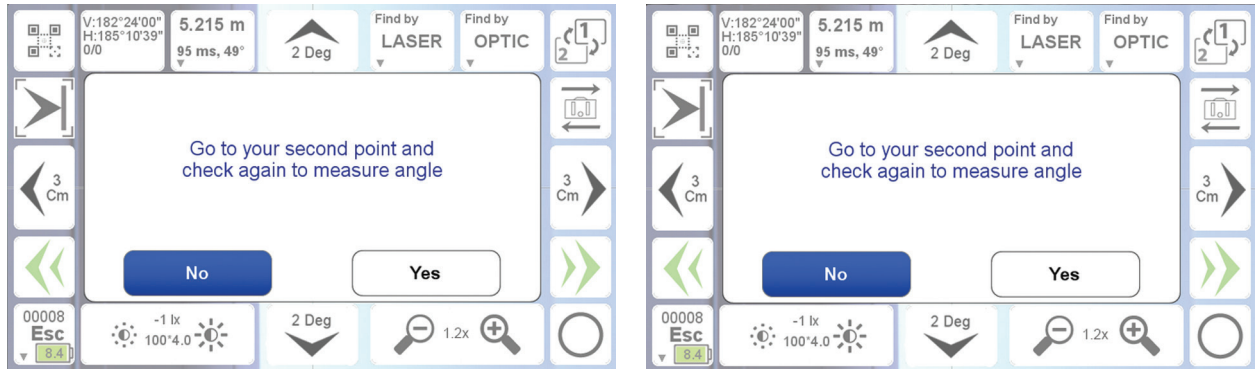

## Saving and Recalling Orientations:

Aim at a point and click button “17” of the Figure 1 to save the horizontal, vertical, or both of that orientation (Figure 6). Click button “16” to rotate to that saved orientation.

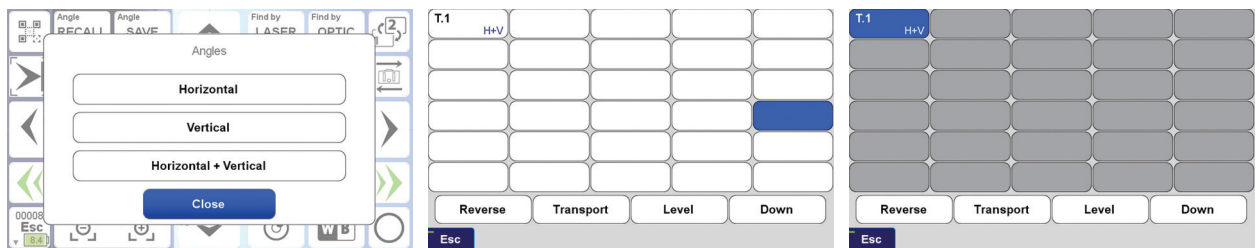

Figure 6

## Scanning and snapping to an object:

Click button “15” of Figure 1 and see that the left and right motion buttons (“14” on Figure 1) change to red which means when you click them scanning to snap will start. Hold long button “15” to get to the screen.

In this screen you can define the scan range and ask the scan to stop when range changes by the specified value and snap to it. Then you can select to save the point that was measured before the stop or after the snap.

You can scan the ranges that you have specified and record the 3D image. When you click button 15 to end the scanning mode, you will be asked if you want to save the scanned file.

You can view the 3D image of the scanned file in the “File” icon of the Home screen of the TRIUMPH-LS as shown at the end of this article.

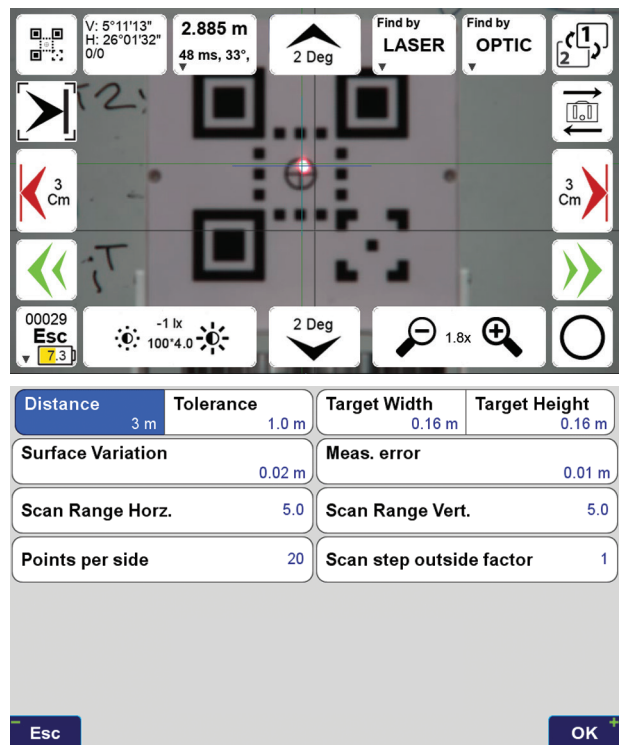

## Connecting and Re-connecting J-Mate to TRIUMPH-LS

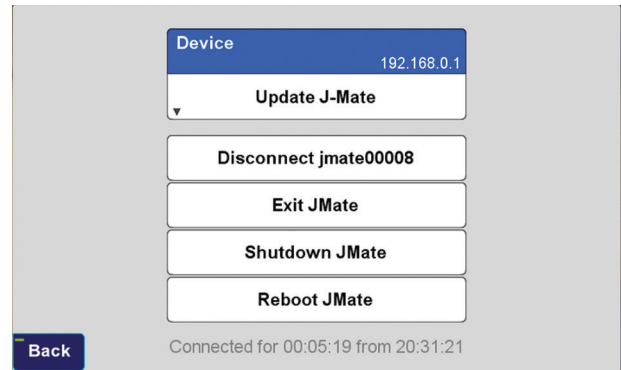

Figure 7

Holding the button “13” or “15” in Figure 1 which will take you to the set up screen and then to Figure 7 which lets you disconnect J-Mate, Reboot, or turn off. Like all Wi-Fi connections, you may lose connection and need to use this screen to disconnect, re-connect, or re-boot J-Mate and in some occasions reboot TRIUMPH-LS too, especially when connection between the camera of the J-Mate and TRIUMPH-LS is lost.

## View range and angular measurements

Boxes “2” and “3” of the Figure 1 show the range and angular measurements. It reads up to 20 times per second. Click box 3 to enter the measured offsets between the two cameras.

## Automatic finding of the Target:

Click the J-Target icon (“1” of the Figure 1). You will be guided through the following steps to aim at your target point:

1. Put the TRIUMPH-LS on top of J-Mate (or slightly above it, but at the same orientation as the J-Mate, to be far from the motor magnets of the J-Mate) and click Next.

This step will transfer the compass reading of the TRIUMPH-LS to the J-Mate encoders.

You can skip this and the next step if you are in an area that the compass readings are not valid or you can aim manually in the next steps.

2. Go to your target, Put the J-Target on top of the TRIUMPH-LS and aim the TRIUMPH-LS towards the J-Mate (with the help of the TRIUMPH-LS camera) and click Next.

This will help the J-Mate to know the general direction to the target and limit its search range. You can go back to previous step to fine tune view of the J-Mate. Or you can skip these two steps.

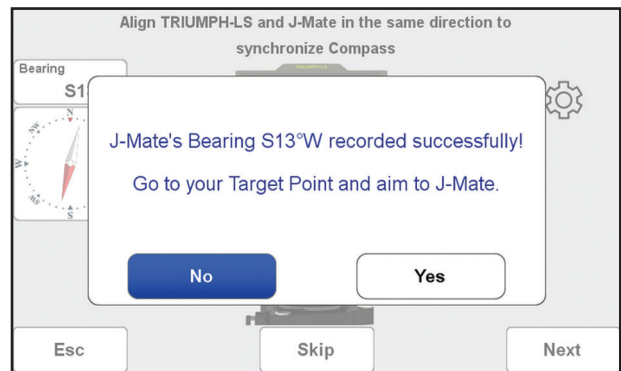

3. You will see the J-Mate camera view on the TRIUMPH-LS screen. You can fine tune the J-Mate view by the navigation buttons to make recognition faster. You can skip these steps if you don't want to make the search faster.

In here you can also manually aim at the center of the J-Target panel and take your shot.

4. Click "Optic" if you want the J-Target panel to be scanned and centered automatically.

When J-Mate focuses on the center of the J-Target, you can click the "Take" button. You will be asked if you want to record the point.

5. If you also want to find the center of the J-Target by Laser scanning, you can click the "Laser". If Laser scan is successful, you can click the "Take" button to replace the previous measurement with the current measurement done by laser scanning.

The center of the J-Target is vertically collocated with the GNSS antenna and you don't need to be exactly perpendicular to the J-Mate path.

If light condition is such that camera cannot find the J-Target, chances are better that laser scanner can find it.

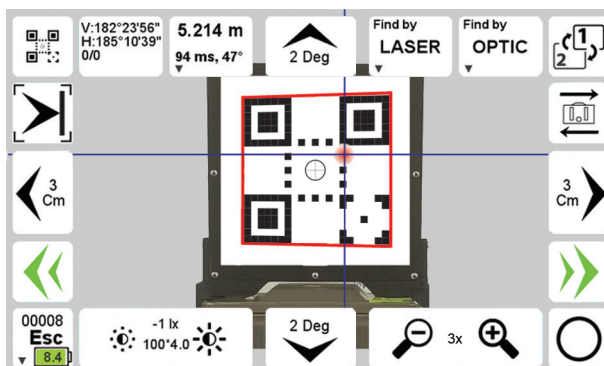
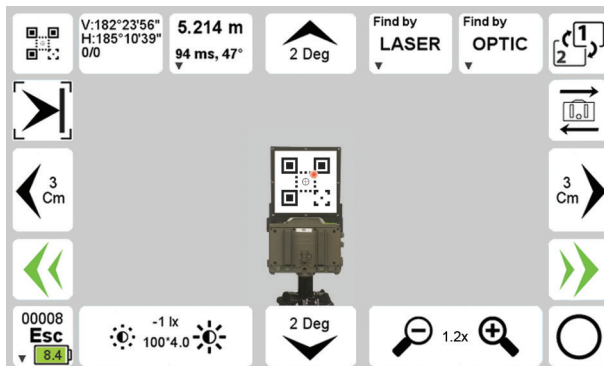

### View scanned Images:

You see the 2 views of the 3D scanning

The first scan image is scan of a 1 cm thick and a 6 cm thick objects. 1 cm step resolution.

The last one is scan of a 12.5 x 8 cm object of 1 cm thickness.

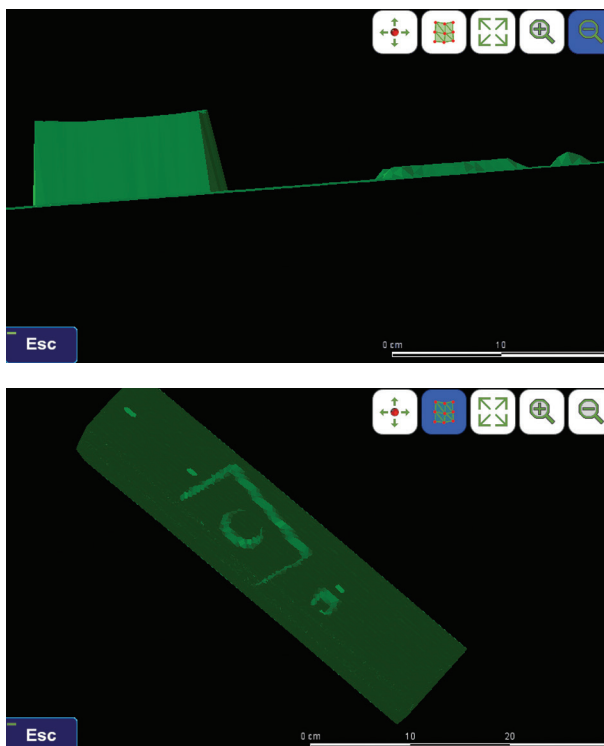

This overview as also an update to videos at [www.javad.com](http://www.javad.com).

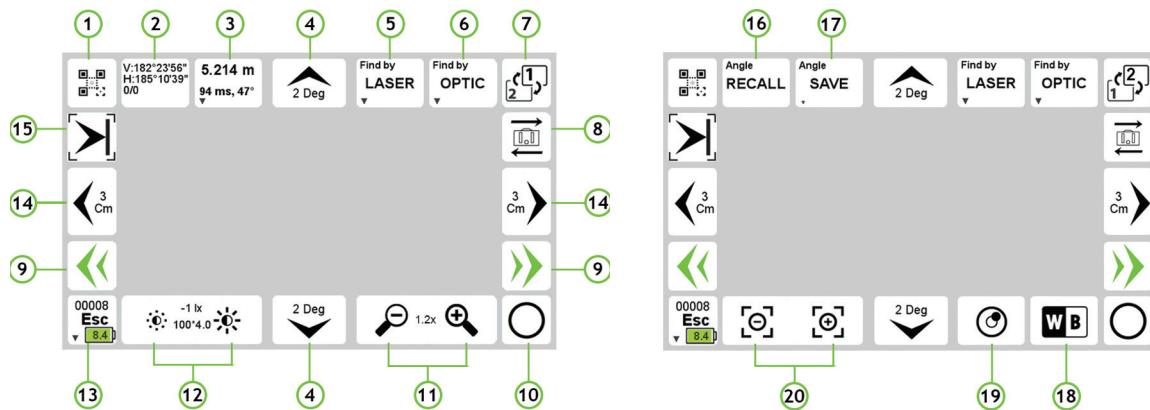

Figure 1

## This is the Main Navigation Screen.

Clicking the button “7” in Figure 1 will switch some controls as shown above.

## Aiming at Targets:

You can find targets manually or automatically.

There are five ways that you can manually rotate the J-Mate towards your target:

1. There are Left/Right/Up/Down buttons around the screen (“4” and “14”). Each click moves the J-Mate according to the value that you assign to them in the setup screen, as shown in Figure 2.

2. While holding these buttons down, J-Mate rotates about 5 degrees per second.

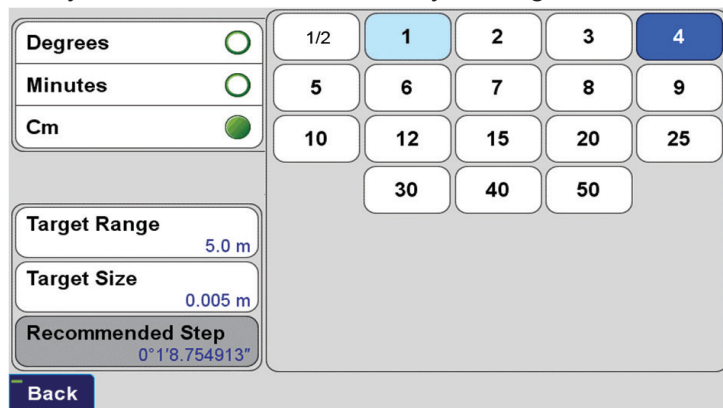

Figure 2

3. Buttons “9” are “Fast Motion” buttons. While you hold them the J-Mate rotates about 30 degrees per second.

4. You can point J-Mate towards points by touching points on the screen and by gestures.

5. You can also rotate the J-Mate manually while it is not moving automatically, but limit that to the small rotations, not to apply backpressure to motor.

Motor manufacturer does not prohibit manual motion, but we think it is better to avoid it as much as possible.

# TRIUMPH-3

The new TRIUMPH-3 receiver inherits and builds on the best features of our famous TRIUMPH-1M.

Based on our new third generation a TRIUMPH chip enclosed in a rugged magnesium alloy housing.



The TRIUMPH-3 receiver can operate as a portable base station for Real-time Kinematic (RTK) applications or as a receiver for post-processing, and as a scientific station collecting information for individual studies, such as ionosphere monitoring and the like.

It includes options for all of the software and hardware features required to perform a wide variety of tasks.

- UHF/Spread Spectrum Radio
- 4G/LTE module
- Wi-Fi 5 GHz and 2.4 GHz (802.11 a, b, g, n, d, e, i)
- Dual-mode Bluetooth and Bluetooth LE
- Full-duplex 10BASE-T/100Base-TX Ethernet port
- High Speed USB 2.0 Host (480 Mbps)
- High Speed USB 2.0 Device (480 Mbps)
- High Capacity microSD Card (microSDHC) up to 128GB Class 10;
- “Lift & Tilt”
- J-Mobile interface



**Ideal as a base station**